



**PLANMECA**  
ProMax 3D



## *Profound understanding of anatomy*



Planmeca ProMax 3D, the intelligent and multipurpose X-ray unit, is designed to obtain complete information on patient anatomy in the minutest detail. The unit provides digital panoramic, cephalometric, and 3D imaging, as well as advanced imaging software tools to comply with every possible need in dental radiology. The Planmeca ProMax concept is unique in that the 3D imaging modality is available with a simple upgrade of a digital Planmeca ProMax. As a result, one intelligent X-ray unit can meet virtually any need in maxillofacial imaging.



The direct deposit CsI coated semiconductor flat panel produces accurate, distortion-free images for 3D reconstruction. Unlike image intensifier sensors that use old vacuum tube technology and multi-step focusing, flat panels use single step image readouts with no geometric distortion, no loss of sensitivity, and therefore no need for frequent calibration.

Planmeca's proprietary 3D reconstruction algorithm converts the original 2D transillumination images to 3D volume study and is the core component for

high quality 3D imaging. It handles high contrast objects, like amalgam fillings, in a special way in order to produce undisturbed study views.

The reconstructed image volume consists of more than 120 million voxels. These voxels are isotropic, which enables accurate 1:1 measurements and ensures geometric relations throughout the image.

The extremely small voxel size,  $160^3 \mu\text{m}^3$ , provides a detailed high-resolution 3 lp/mm image without artefacts.



In modern dentistry, the demand for surgical implant treatments is steadily growing. The growth trend has created a need for a more advanced X-ray imaging device. Planmeca ProMax 3D, a Cone Beam Volumetric Tomography (CBVT) unit, is expressly designed to comply with the needs of modern surgical dentistry. It supplies clear, dependable imaging in a three-dimensional format with limited patient radiation dose.

Thanks to its small footprint, Planmeca ProMax 3D makes effective three-dimensional imaging possible in every dental practice. Planmeca ProMax 3D is a genuine all-in-one unit including digital panoramic, digital cephalometric, and 3D digital imaging, all in the same unit, saving office space and investment costs. This innovative, versatile, and dynamic imaging device will open up new possibilities for dentists on-site in their offices.

Planmeca ProMax 3D uses new Cone Beam Volumetric Tomography technology, in which the X-ray beam used is shaped in the form of a cone or a pyramid. The CBVT technology takes the whole volume needed in a single semicircle scan, as opposed to a medical CT that takes multiple axial slices in multiple full circle scans.

During the scan, each image is made using a short X-ray pulse instead of continuous radiation. The total scanning time is 18 seconds for one volume, but the actual exposure time is only 3 seconds at shortest. This technique reduces patient radiation dose considerably and forms stroboscopic X-ray effect which, together with the shortened rotation scan (only 200 degrees), virtually eliminates artefacts contributing to outstanding image quality.

The Planmeca ProMax platform's unique SCARA technology (Selectively Compliant Articulated Robot Arm) enables free formation of the imaging geometry. Planmeca's patented, computer-controlled SCARA robotic arm can produce any movement pattern required, ensuring perfectly accurate and reliable image volume positioning. All controls are made on a full colour graphical user interface in the language of your choice.

Thanks to the original, technologically advanced design, any Planmeca ProMax can be upgraded into a 3D Cone Beam Volumetric Tomography unit.

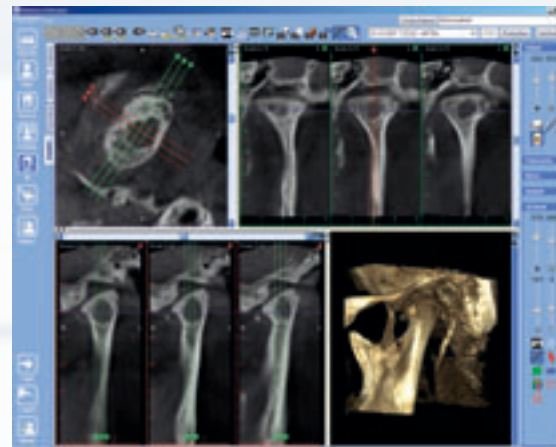

**TMJ study**  
The condyle is displayed sharply. The image clearly shows the condition of the temporomandibular joint. Malign finding can be seen inside the condyle head.

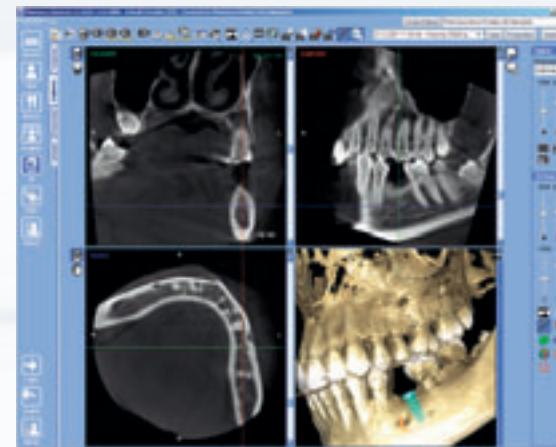

**Implant case**  
The lower first molar on the right is missing. The image clearly shows that there is enough bone to place an implant.

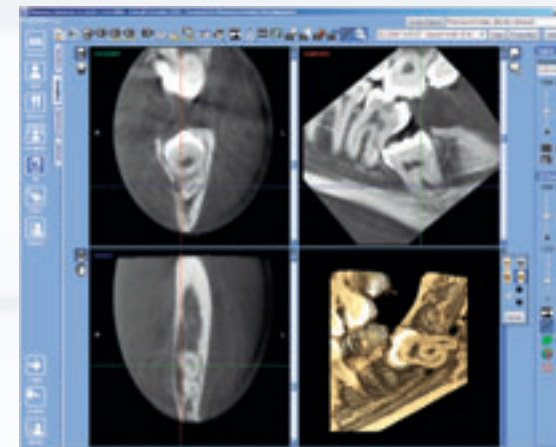

**Wisdom tooth extraction**  
It is easy to see that the extraction would be difficult. The mandibular canal is located lingually to the roots.

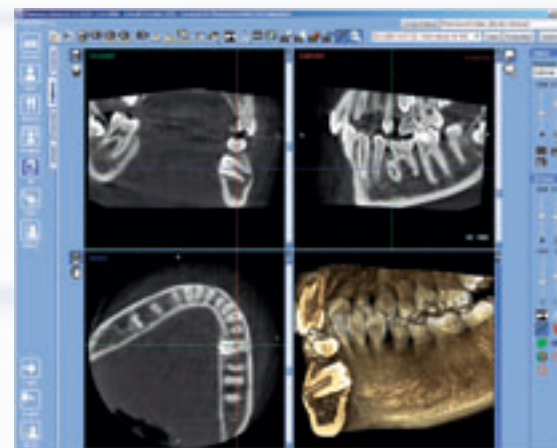

**Impacted canine**  
An impacted maxillary right canine found in the wall between sinus and nasal cavity.

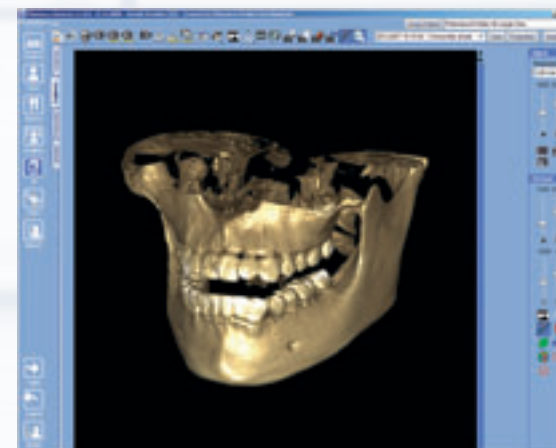

**Large View image**  
Three volumes stitched together for a full view.

Planmeca ProMax 3D complies with a multitude of diagnostic requirements: those of endodontics, periodontics, orthodontics, implantology, dental and maxillofacial surgery, and TMJ analysis. It is also an excellent tool for diagnosing ear, maxillary sinus, and respiratory tract diseases.

With Planmeca ProMax 3D, study volume sizes can be selected to meet diagnostic needs without excess radiation outside the area of interest.

The 80 x 80 mm image size is optimum for most diagnostic applications that require whole dentition, mandible, and maxilla in the same study volume. The 80 x 50 mm volume can be used for single views of the mandible or maxilla, lowering the radiation by almost 40%. The small 40 x 50 mm volume is intended for molar area studies or for planning 3<sup>rd</sup> molar extractions.

The volumes can also be stitched together to generate an image up to 140 mm in width or 140 mm in height.

Planmeca ProMax 3D produces high-resolution volumetric studies of the mandible and maxilla for analysing the bone structure available, the location of the mandibular canal, and the correct position for the implant. Pre-surgical planning will reach a new level of precision, as the prospective site is visible in all three imaging planes: sagittal, axial, and coronal.

Third molars, maxillary cuspids, supernumerary teeth, and all of impactions challenge the clinician to identify the tooth's orientation. With Planmeca ProMax 3D all angles and orientations become clearly visible.

Planmeca ProMax 3D studies accompanied by digital cephalometric images provide full visualisation of all classes of orthodontic malocclusion. This is highly

advantageous for orthodontic planning, as time is saved and patient radiation dose reduced. Unlike traditional orthodontic analyses, Planmeca ProMax 3D provides the orthodontist with image data in the correct anatomic 1:1 ratio, without need to correct for geometric magnification.

Planmeca ProMax 3D also provides high-resolution TMJ studies for true and accurate evaluations of the joint arthritides, condylar morphology, and the condyle-fossa relationship.

With its high resolution (3 lp/mm) and advanced reconstruction technology, Planmeca ProMax 3D establishes the new standard for 3D dental radiology.

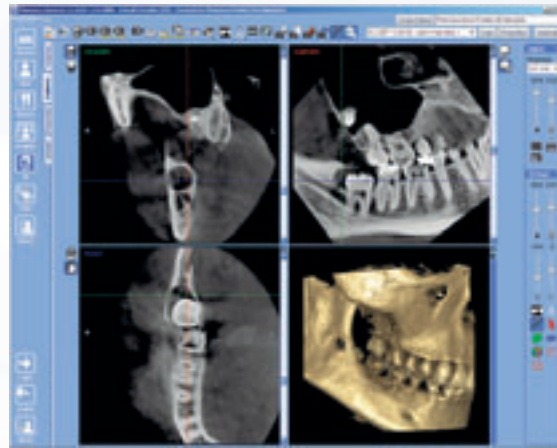

**Cyst in right mandible**  
A large solitary bone cyst is clearly visible in the right mandible.

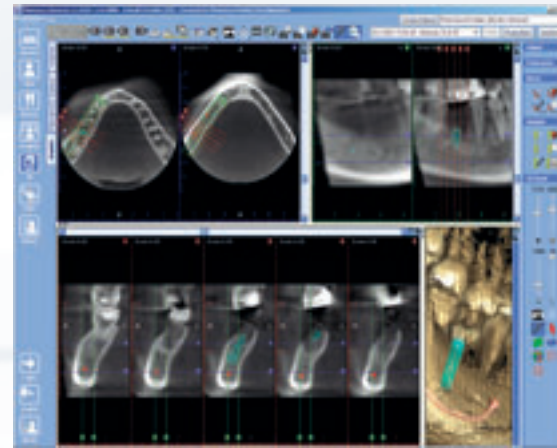

Planmeca Romexis 3D Implant Planning module

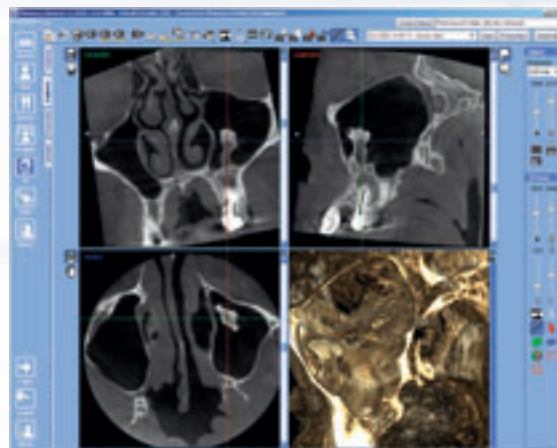

**Sinus study**  
A cyst and inflammation can be found in the left maxillary sinus.

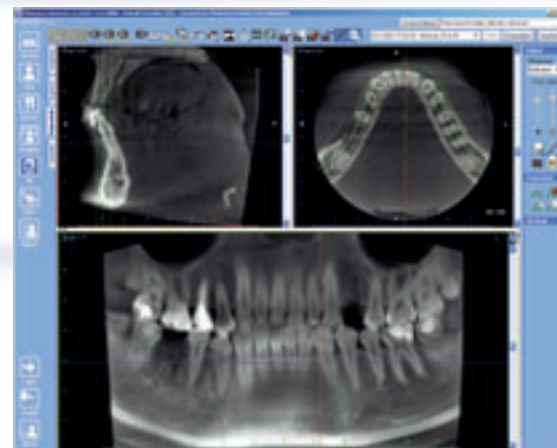

Planmeca Romexis 3D Panoramic module

Planmeca Romexis 3D Explorer, the 3D image acquisition software for Planmeca ProMax 3D, enables flexible viewing in all three relevant projections: axial, coronal, and sagittal. The software incorporates a re-slicing feature, which enhances the projections and enables real-time three-dimensional viewing in the desired angle. A rendered 3D view provides a realistic overview of the anatomy.

With the Planmeca Romexis 3D Explorer software, each patient study can be stored on a CD with Planmeca Romexis 3D Viewer for others to view.

The optional Planmeca Romexis 3D Panoramic module creates a panoramic image from the acquired

volume of data without the undesired artefacts, common in normal panoramic images. As the image is reconstructed through software, the user can determine the location and thickness of the focal trough.

The Planmeca Romexis 3D Cross Sections module, which is available as an option, produces cross-sectional images of anatomy along with the defined panoramic curve. The image number and their exact positions can be freely chosen. The 3D Cross Sections module also includes the reconstructed panoramic view.

The optional Planmeca Romexis 3D Implant Planning module offers tools for implant placing and nerve drawing. The implant placements are determined with

the help of an implant model corresponding to the actual size of the real implant. A drawing tool allows clear marking of the mandibular nerve.

Planmeca Romexis software has optional DICOM functionality, which allows 3D studies to be transferred to other implant planning software, such as SimPlant, Nobel Biocare Procera, CyberMed, or any other software that receives images in DICOM format. Studies can also be transferred to PACS or to a high quality DICOM printer in the network.

Planmeca Romexis is a pure Java based software that runs in various operating systems and modern web environments.



### Planmeca Romexis software

Planmeca Romexis is a complete dental imaging software, including all dental imaging modalities: intraoral, panoramic, cephalometric, 3D imaging, dental tomography as well as intraoral video and still camera imaging. With a complete set of tools for image viewing, enhancement, measurements, and annotations, Planmeca Romexis also improves the diagnostic value of radiographs. Printing, image import and export, and DICOM functionalities are also included.

Planmeca Romexis platform fully integrates digital imaging with the patient's other clinical data. The system provides direct image capture from Planmeca's X-ray equipment, and interfaces with 3<sup>rd</sup> party devices via TWAIN. Together with Planmeca's X-ray equipment, Planmeca Romexis provides a unique safety feature especially useful for teaching environment: the X-ray image capture is inhibited until the supervisor has approved the student's image capture request.

### Planmeca Romexis computer recommendations

	Planmeca Romexis client work station	Planmeca Romexis server
Processor	2 GHz Core Duo or equivalent	3 GHz Core Duo or equivalent
RAM	3 GB	3 GB
Hard disk space	40 GB	2 x 500 GB (RAID1 mirroring)
Graphics card	ATI or NVIDIA, 128 MB minimum memory	Not required
Monitor	1280 x 1024	1024 x 768
Peripherals	CD R/W or DVD R/W drive	CD R/W or DVD R/W drive
Backup medium	None necessary	DAT or equivalent
Operating system	Windows XP, Windows 2003, Windows Vista, Mac OS X, Linux Mac OS X / Linux support subject to contract	Windows XP Pro, Windows 2003 Server, Windows Vista
Other	Java platform (Java Virtual Machine 1.6 or later)	Java platform (Java Virtual Machine 1.6 or later)

The disk space requirements are dominated by digital images. Thus the space requirements vary, but a rough estimate is in the order of 1 MB per 2D X-ray image, 7–9 MB per extraoral image, depending on a variety of image specific factors, and 250 MB per 3D image.

It is recommended to use the same computer for application server and for database server. If Planmeca Romexis server computer is also used for client activities, the hardware should meet both client and server specifications.

Values presented above are recommended minimum specifications, not meeting them may in some cases cause degraded performance.

### DICOM compatibility

- Media Storage – saving images into removable DICOM media
- Print – printing images on film or paper with a DICOM medical printer
- Storage – saving images into DICOM image archive
- Query/ Retrieve – importing digital images from DICOM image archive
- Worklist – importing a patient list from DICOM patient management
- Storage Commitment – confirmation of a successful image storage

### Planmeca ProMax 3D

X-ray beam	Cone
Focal spot	0.5 mm, fixed anode
Image detector	CsI coated CMOS flat panel sensor
Gray scale	15 bit
Detector resolution	624 x 624 pixels, pixel size 200 µm x 200 µm
Voxel size	160 x 160 x 160 µm, isotropic 320 x 320 x 320 µm, isotropic
Image acquisition	Single 200 degree rotation
Total scan time	18 s, pulsed X-ray
Reconstruction time	30–150 s
Standard volumes (diam. x height)	Ø80 x 80 mm Ø80 x 50 mm Ø40 x 50 mm
Stitched volume (diam. x height)	Ø140 x 140 mm
3D reconstruction server	Proprietary Feldkamp type back projection reconstruction algorithm Improved Artifact Removal (IAR) High Contrast Object Compensation (HCOC)

### Example installation

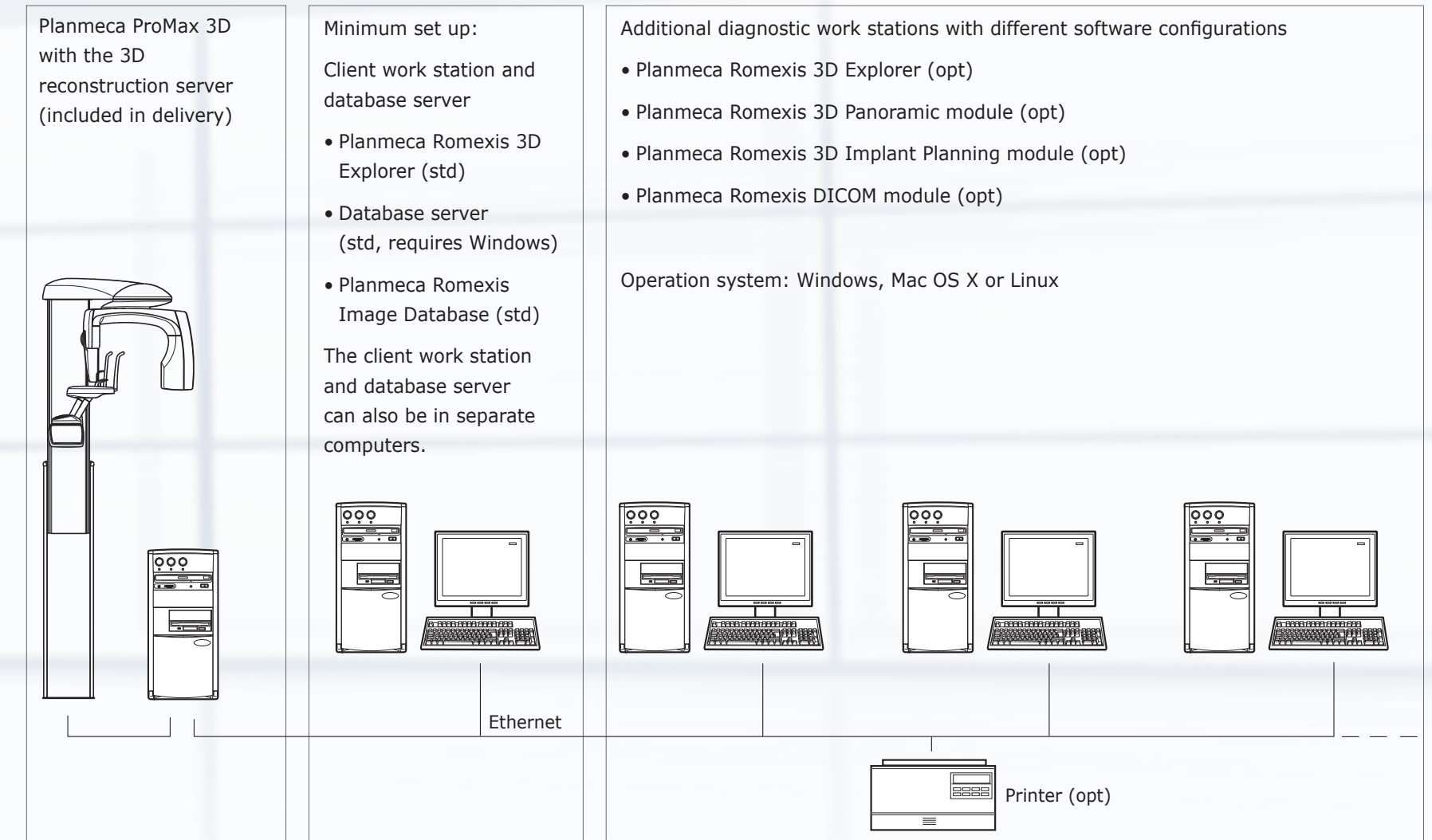

### Dimensions and space requirements

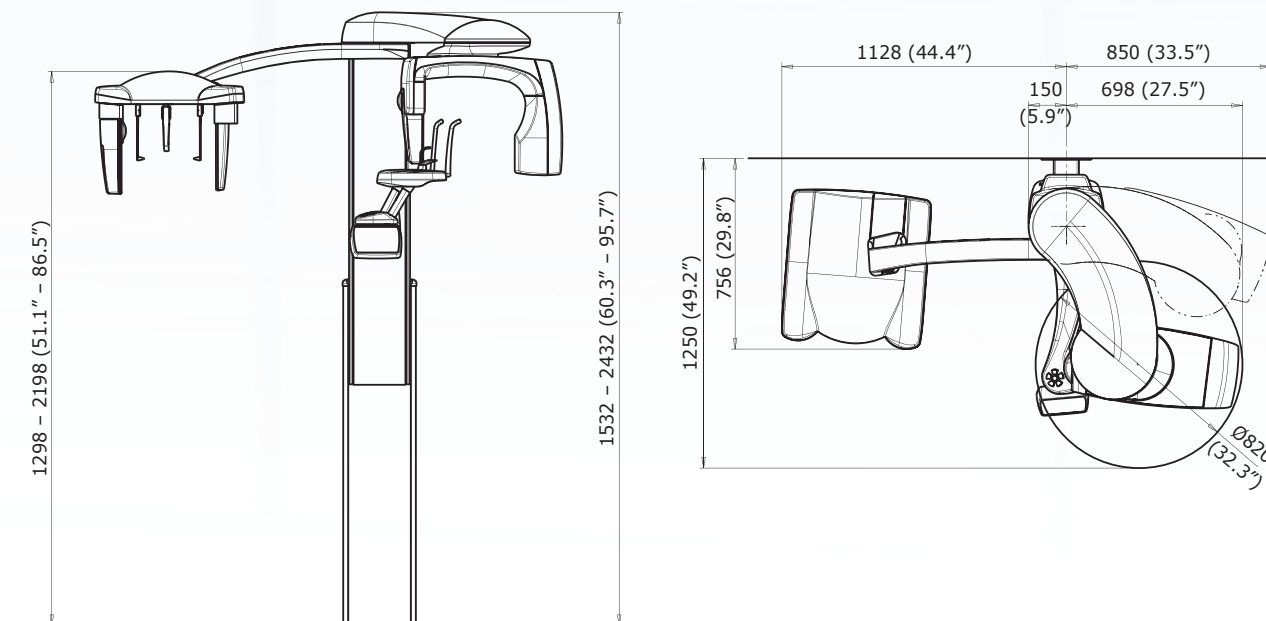

		Planmeca ProMax 3D	Planmeca ProMax 3D with cephalostat
Physical space requirements	Width	96 cm (38 in.)	194 cm (76 in.)
	Depth	125 cm (49 in.)	125 cm (49 in.)
	Height*	153–243 cm (60–96 in.)	153–243 cm (60–96 in.)
Minimum operational space requirements	Width	150 cm (59 in.)	215 cm (85 in.)
	Depth	163 cm (64 in.)	163 cm (64 in.)
	Height*	243 cm (96 in.)	243 cm (96 in.)
Weight		113 kg (lbs 248)	128 kg (lbs 282)

\*The maximum height of the unit can be adjusted for offices with limited ceiling space.



*Planmeca Oy designs and manufactures a full line of high technology dental equipment, including dental care units, panoramic and intraoral X-ray units, and digital imaging products. Planmeca Oy, the parent company of the Finnish Planmeca Group, is strongly committed to R&D, and is the largest privately held company in the field.*



Planmeca Oy  
 Asentajankatu 6 | 00880 Helsinki | Finland  
 tel. +358 20 7795 500 | fax +358 20 7795 555  
 sales@planmeca.com | www.planmeca.com

Images may contain optional items not included in standard delivery. Available configurations and features may have country or area specific variations. Some products displayed above may not be available in all countries or areas. Rights for changes reserved.